

CENTURION® POLARIS

WATERTIGHT CARRYING CASES TO MIL-STD-108*

The watertight Centurion® Polaris Series from ZERO Manufacturing, Inc. features deep-drawn heat-treated aluminum case shells with wrinkle-free surfaces, accented by distinctive styling beads. Sturdy and durable. Centurion Polaris cases are strong enough to stand on, yet are ultra-lightweight.

Polaris Cases are available in a variety of heights, finishes and with a choice of closures, and three different panel mounting flanges. For the ultimate in watertight carrying cases, choose ZERO's Centurion® Polaris series case.



FEATURES

- ▶ Watertight
- ▶ Gasketed Closures
- ▶ Separable Hinges to Remove Cover
- ▶ Closure features interlocking tongue and groove extrusion of 6063-T1 aluminum, permitting maximum sealing and alignment of two halves.

OPTIONS

- ▶ Hinged inner lids available as special order item.
- ▶ Panel Mounting Flange
- ▶ Panel Fabrication
- ▶ Mil-Spec Finishes
- ▶ Custom Engraving, Marking, Labeling

*Except to 0.50 PSI



Case shown with optional feature.

FINISH OPTIONS

Note: Except latches, handle, grip, hinges, valve.

POWDER COAT PAINT RECOMMENDED

- BK—Black 27038
- DB—Dark Blue 25045
- DS—Desert Sand 20372
- FG—Forest Green 24079
- GR—Gray 26307
- MB—Medium Blue 25190
- NG—NATO Green RAL6014
- OD—Olive Drab 24097
- OR—Orange 21400
- RD—Red 21105
- WH—White 27925
- YW—Yellow 23538

FED-STD-595 for reference.

RHINOLINING™

- RB—Black
- RG—Gray

MIL-SPEC FINISHES

- A—No Finish.
- B—Chemical Film Per MIL-DTL-5541, Type I, Class 1A. Epoxy Primer per MIL-PRF-23377, Type 1, Class C2.
- C—Same as B Plus Paint Light Gray Semi-Gloss Polyurethane Color #26307 of FED-STD-595.
- D—Same as B Plus Paint Light Gray Semi-Gloss Polyurethane Color #16307 of FED-STD-595.
- E—Wash Prime per DOD-P-15328 and Epoxy Primer per MIL-DTL-53022, Type II, Paint Polyurethane Yellow Gloss Color #13538 of FED-STD-595.
- F—Same as B Plus Paint Strata Blue Gloss Polyurethane Color #15045 of FED-STD-595.
- G—Same as B Plus Paint Green Semi-Gloss Polyurethane Color #24300 of FED-STD-595.

MIL-SPEC FINISHES cont.

- H—Same as B Plus Paint Olive Drab Semi-Gloss Polyurethane Color #24084 of FED-STD-595.
- J—Same as B Plus Paint Olive Drab Lusterless Polyurethane Color #34088 of FED-STD-595.
- K—Same as B Plus Paint Aliphatic Polyurethane Camouflage Coating (CARC) per MIL-DTL-53039, Type II, Color #383 Green, #34094 of FED-STD-595.
- S—Special Order—Please Specify.
- W—Chemical Film Per MIL-DTL-5541, Type I, Class 1A. Epoxy Primer per MIL-DTL-53022, Type II, or Water-base Epoxy Primer per MIL-DTL-53030, Type I. Paint with White Polyurethane Coating per MIL-PRF-85285, Type II, Class H, Color #17925 of FED-STD-595 or Epoxy Coating Per MIL-PRF-22750.
- UA—Chem Film per MIL-DTL-5541, Type I, Class 1A.

OTHER COLORS AND FINISHES AVAILABLE ON REQUEST

Commercial or military specification can be met in our completely equipped and staffed paint facility. In addition to supplying any color per FED-STD-595, PMS or RAL. ZERO has coded swatches to match any color.

PANEL FABRICATION

- Silk-Screening
- Engraving
- Custom Fabrication

CASE CUSTOMIZATION

- Stenciling
- Designation Printing
- Decals and Labels
- Silk-Screening

ORDER STOCK OR CUSTOM SIZES

CALL TOLL FREE 800.959.5050

quotes@zerocases.com | www.zerocases.com

Fax 801.299.7389 | Direct 801.298.5900

CENTURION® POLARIS

CASE DESCRIPTION AND HARDWARE

Basic Shell Dimensions. Available in Varying Height. Contact ZERO for Design Assistance.

CASE NUMBER	EXTERIOR		INTERIOR		D	E	F	G	H	R1	R2	R3	R4	MATERIAL THICKNESS
	A WIDTH	B LENGTH	C MIN	C MAX										
Z100P	9.00	12.00	2.50	3.36	3.50	1.75	1.34	2.81	0.09	1.00	1.00	6.00	1.00	0.040
Z101P	9.00	16.00	2.50	5.56	5.50	1.75	1.34	2.81	0.09	1.25	1.00	6.00	1.00	0.051
Z103P	13.00	18.00	2.50	5.91	6.40	2.00	1.75	5.12	0.12	1.25	1.00	6.25	1.00	0.040
Z105P	13.00	21.00	2.50	4.06	7.90	2.00	2.00	5.00	0.12	1.25	1.00	6.25	1.00	0.040
Z106P	17.00	21.00	2.78	4.81	7.46	2.68	2.25	7.13	0.12	1.25	1.25	6.50	1.25	0.051
Z109P	18.00	26.00	2.38	7.31	9.81	3.16	1.63	8.43	0.12	1.00	1.00	6.50	1.00	0.063
Z112P	18.00	24.00	2.78	4.81	8.87	2.93	2.25	7.64	0.12	1.25	1.25	6.50	1.25	0.051
Z114P	17.00	18.00	2.31	4.36	6.40	2.68	2.25	7.14	0.12	1.25	1.00	6.25	1.00	0.040
Z129P	20.00	29.00	2.78	5.02	11.31	2.94	2.25	9.62	0.12	1.25	1.25	6.50	1.25	0.051
Z132P	19.75	8.50	2.50	2.91	—	—	—	—	—	1.25	0.50	—	0.50	0.051

BASIC SHELL DIMENSIONS AND CASE SPECIFICATIONS

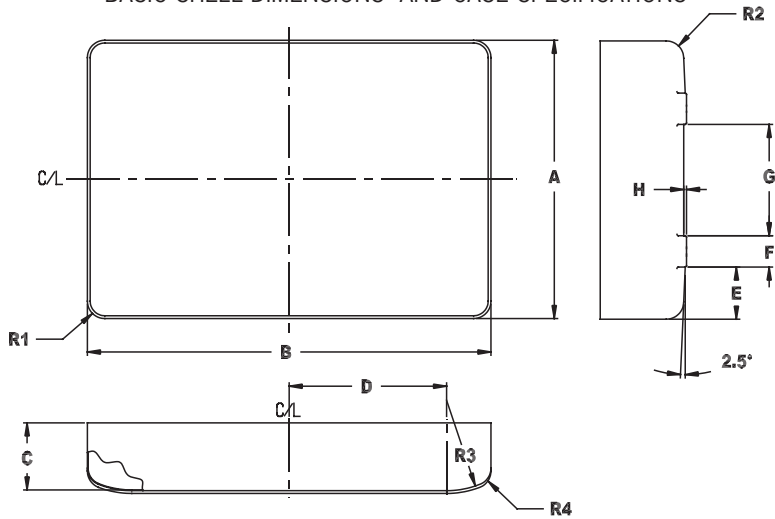

HANDLE

PART #ZSP3-304

- ▶ MATERIAL: 6061 -T6 Aluminum Alloy, Aluminum Plate, Steel Bail with 0.75 rubber grip
- ▶ WEIGHT: 0.183 lbs
- ▶ PERFORMANCE DATA: Design Load 50 lbs. Bail has 180° free swing

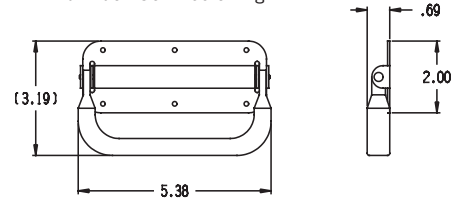

FEET

PART #ZP20118

- ▶ MATERIAL: 6061 -T6 Aluminum Alloy
- ▶ WEIGHT: 0.06 lbs

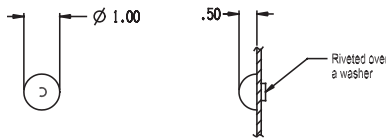

LATCH

PART #TC82Z20-01

- ▶ MATERIAL: Cold Rolled Steel
- ▶ WEIGHT: 0.108 lbs
- ▶ PERFORMANCE DATA: Positive Locking Bail Type



HINGE

PART #ZP20281-1 Long Pin
PART #ZP20281-2 Short Pin

- ▶ MATERIAL: Stainless Steel
- ▶ WEIGHT: 0.104 lbs
- ▶ PERFORMANCE DATA: Available in Separable Versions

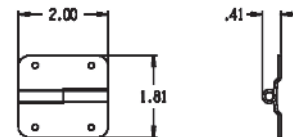

VALVES

PART #ZP20172 Manual Relief Valve

- ▶ MATERIAL: Aluminum Alloy
- ▶ WEIGHT: 0.02 lbs
- ▶ PERFORMANCE DATA: Complies with MS18014-1

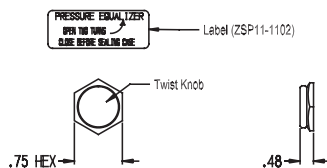

PART #ZSP6-037-1 Automatic Relief Valve

- ▶ MATERIAL: Aluminum Alloy, Stainless Steel Spring
- ▶ WEIGHT: 0.05 lbs
- ▶ PERFORMANCE DATA: Operating Media: Air or Nitrogen Temperature Range: -65° to +160° F Normal Ratings: Vacuum = 3.5 PSI Pressure = 2.5 PSI

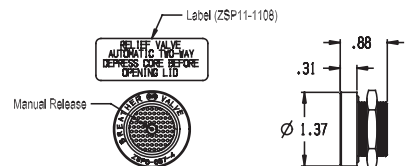

CENTURION® POLARIS

CLOSURE PANEL OPTIONS

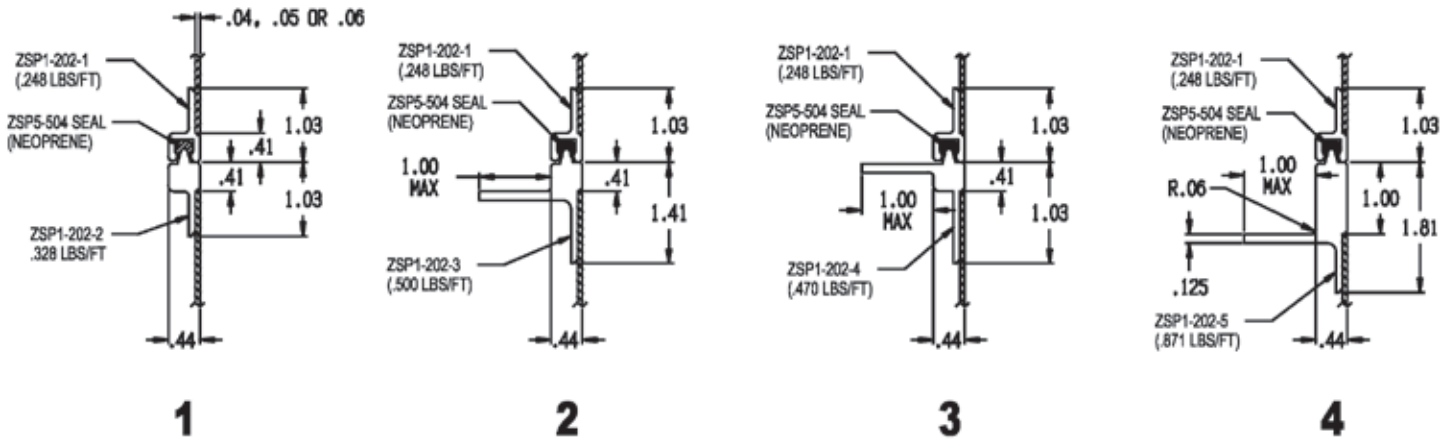

PANEL DIMENSIONS

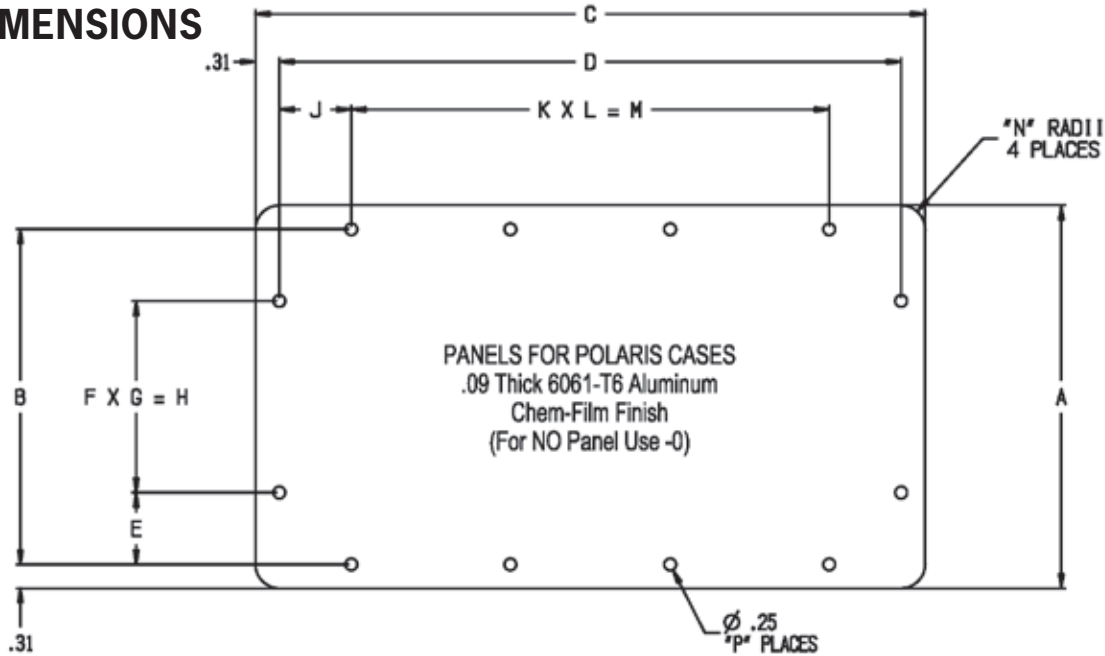

ZP21622 PANEL DIMENSIONS AND DASH PART NUMBERS

DASH NUMBER	CASE SIZE	A	B	C	D	E	F	G	H	J	K	L	M	N	P
-1	Z100P	7.92	7.300	10.92	10.300	1.650	1	4.000	4.000	1.650	2.00	3.500	7.000	0.50	10
-3	Z101P	7.90	7.280	14.90	14.280	1.640	1	4.000	4.000	1.140	3.00	4.000	12.000	0.75	12
-5	Z103P	11.92	11.300	16.92	16.300	1.650	2	4.000	8.000	1.150	4.00	3.500	14.000	0.75	16
-7	Z105P	11.92	11.300	19.92	19.300	1.650	2	4.000	8.000	1.650	4.00	4.000	16.000	0.75	16
-9	Z106P	15.90	15.280	19.90	19.280	1.640	3	4.000	12.000	1.640	4.00	4.000	16.000	0.75	18
-11	Z109P	16.88	16.250	24.88	24.250	1.125	4	3.500	14.000	1.625	6.00	3.500	21.000	0.44	24
-13	Z112P	16.90	16.280	22.90	22.280	1.140	4	3.500	14.000	1.140	5.00	4.000	20.000	0.75	22
-15	Z114P	15.92	15.300	16.92	16.300	1.650	3	4.000	12.000	1.150	4.00	3.500	14.000	0.75	18
-17	Z129P	18.90	18.280	27.90	27.280	1.140	4	4.000	16.000	1.640	6.00	4.000	24.000	0.75	24
-19	Z132P	7.40	6.780	18.65	18.030	1.340	1	4.000	4.000	1.015	4.00	4.000	16.000	0.75	14

POLARIS Z100P

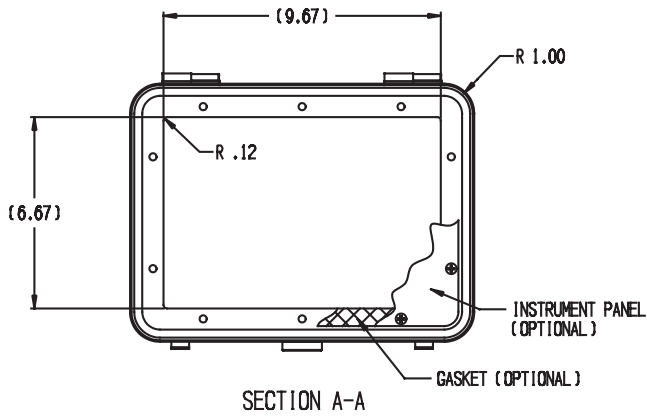

TO ORDER COMPLETE PART NUMBER BELOW:

CASE NUMBER	CLOSURE STYLE	VALVE TYPE	FINISH	OPTIONAL PANEL
100P	●	●	●	●

USE DASH NUMBER FROM PAGE 22

SEE PAGE 20 FOR OPTIONS

A FOR AUTOMATIC
M FOR MANUAL

SEE PAGE 22 FOR OPTIONS

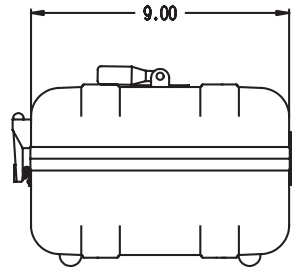
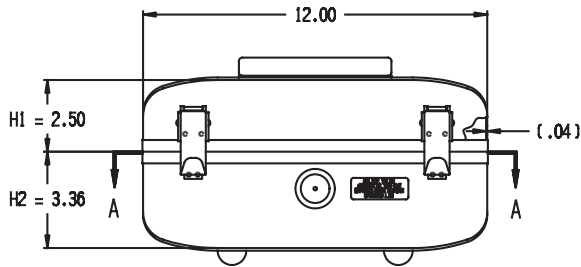

Z101P

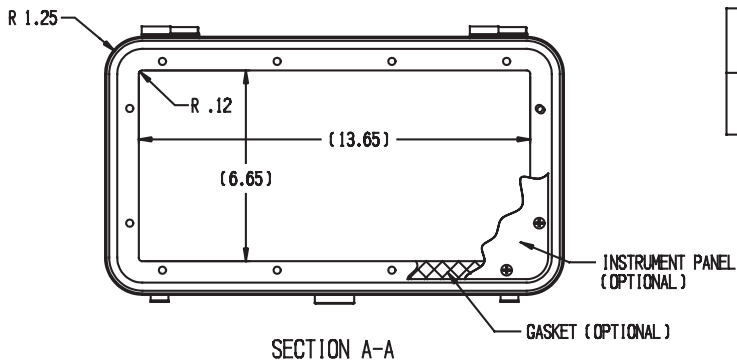

TO ORDER COMPLETE PART NUMBER BELOW:

CASE NUMBER	CLOSURE STYLE	VALVE TYPE	FINISH	OPTIONAL PANEL
101P	●	●	●	●

USE DASH NUMBER FROM PAGE 22

SEE PAGE 20 FOR OPTIONS

A FOR AUTOMATIC
M FOR MANUAL

SEE PAGE 22 FOR OPTIONS

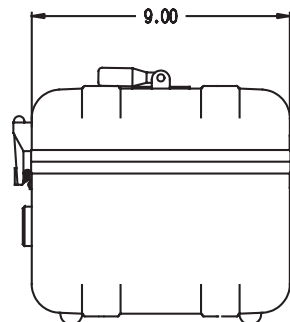
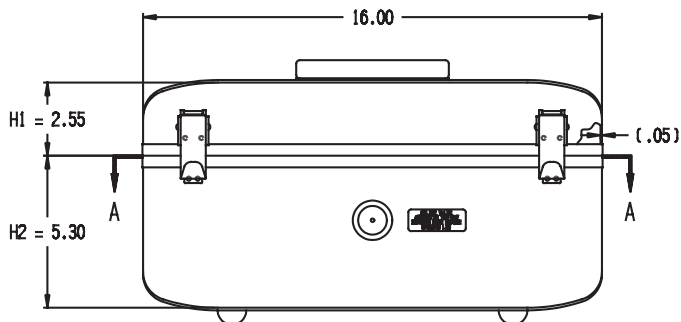

Z103P

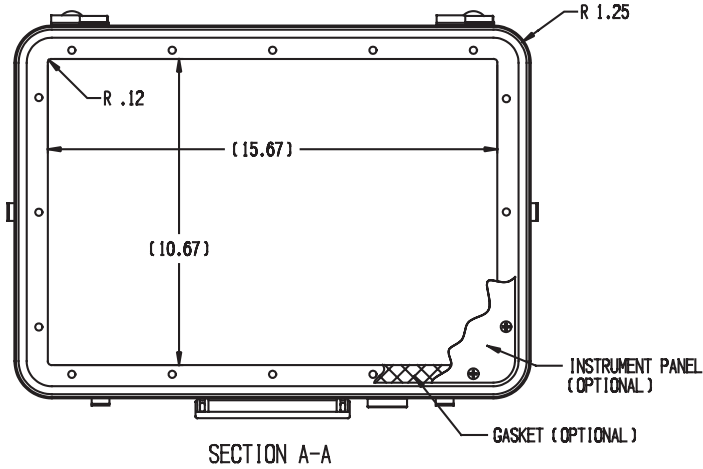

TO ORDER COMPLETE PART NUMBER BELOW:

CASE NUMBER	CLOSURE STYLE	VALVE TYPE	FINISH	OPTIONAL PANEL
Z103P	●	●	●	●

USE DASH NUMBER FROM PAGE 22
SEE PAGE 20 FOR OPTIONS

A FOR AUTOMATIC
M FOR MANUAL

SEE PAGE 22 FOR OPTIONS

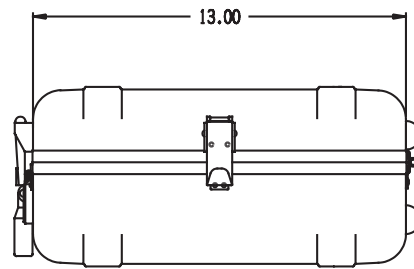
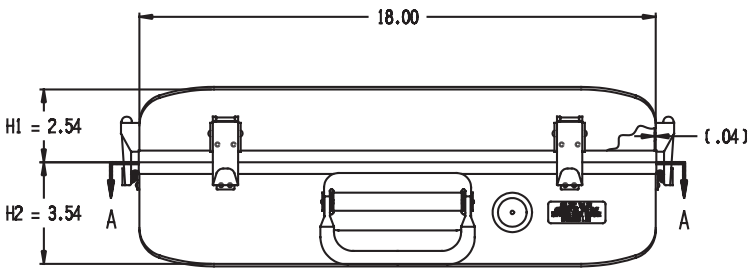

Z105P

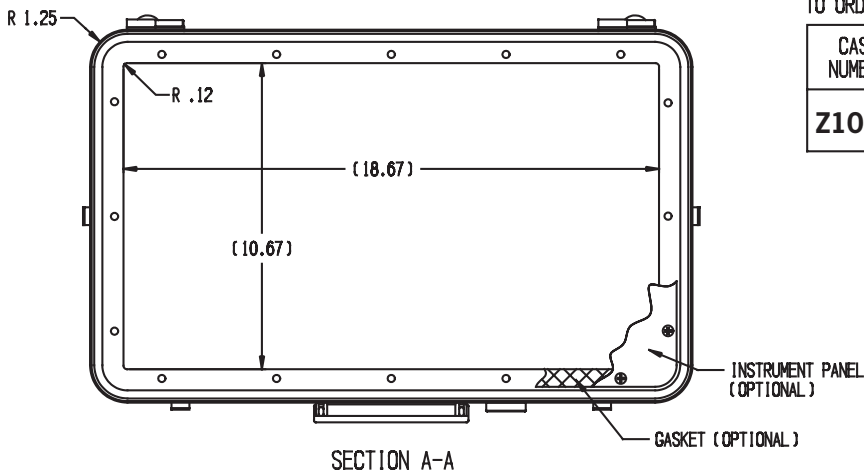

TO ORDER COMPLETE PART NUMBER BELOW:

CASE NUMBER	CLOSURE STYLE	VALVE TYPE	FINISH	OPTIONAL PANEL
Z105P	●	●	●	●

USE DASH NUMBER FROM PAGE 22
SEE PAGE 20 FOR OPTIONS

A FOR AUTOMATIC
M FOR MANUAL

SEE PAGE 22 FOR OPTIONS

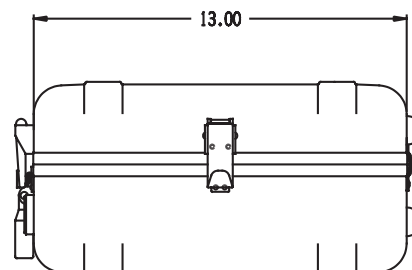
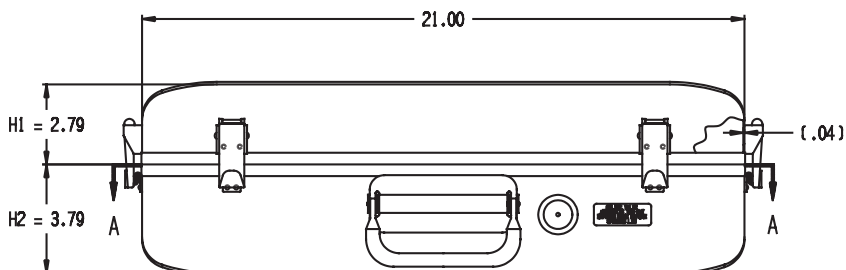

Z106P

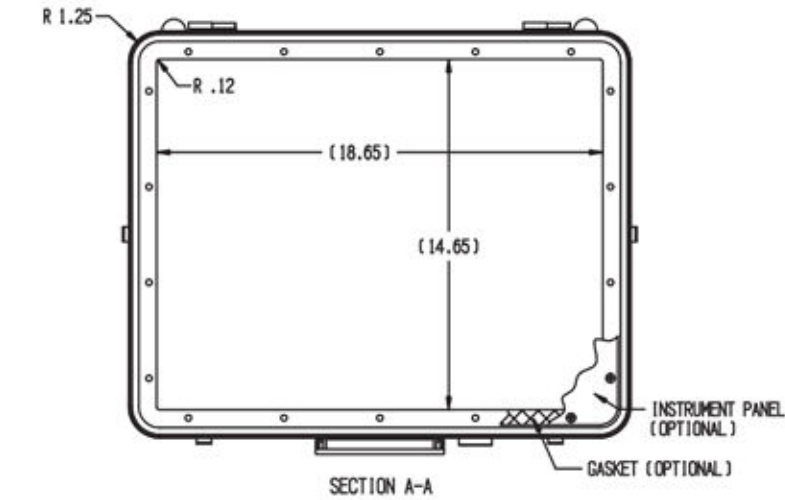

TO ORDER COMPLETE PART NUMBER BELOW:

CASE NUMBER	CLOSURE STYLE	VALVE TYPE	FINISH	OPTIONAL PANEL
Z106P	●	●	●	●

USE DASH NUMBER FROM PAGE 22

SEE PAGE 20 FOR OPTIONS

A FOR AUTOMATIC
M FOR MANUAL

SEE PAGE 22 FOR OPTIONS

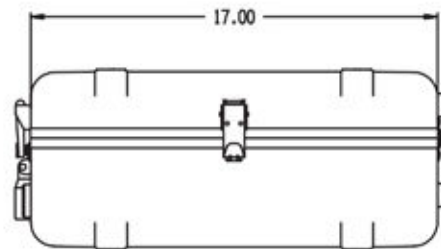
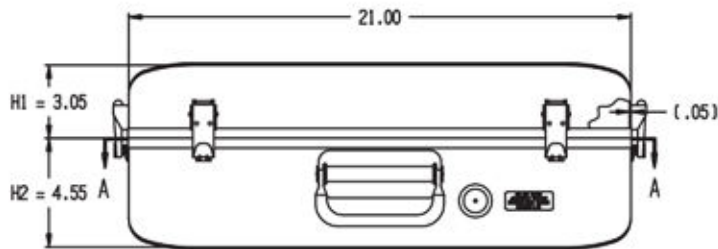

Z109P

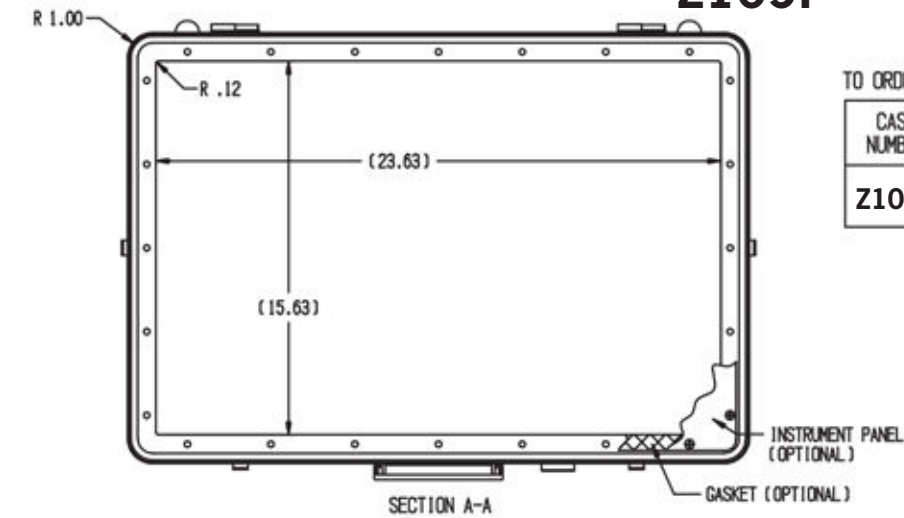

TO ORDER COMPLETE PART NUMBER BELOW:

CASE NUMBER	CLOSURE STYLE	VALVE TYPE	FINISH	OPTIONAL PANEL
Z109P	●	●	●	●

USE DASH NUMBER FROM PAGE 22

SEE PAGE 20 FOR OPTIONS

A FOR AUTOMATIC
M FOR MANUAL

SEE PAGE 22 FOR OPTIONS

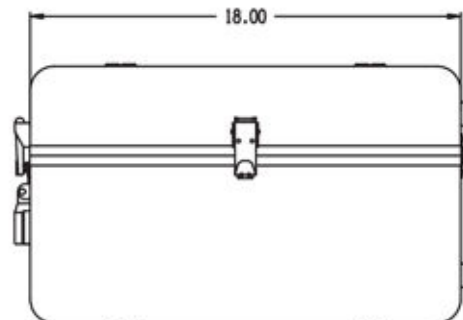
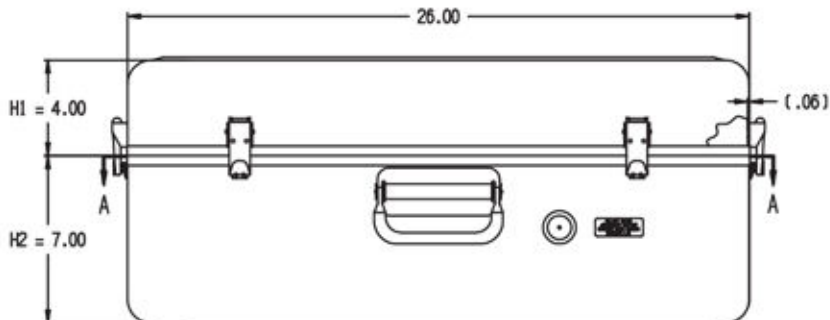

Z112P

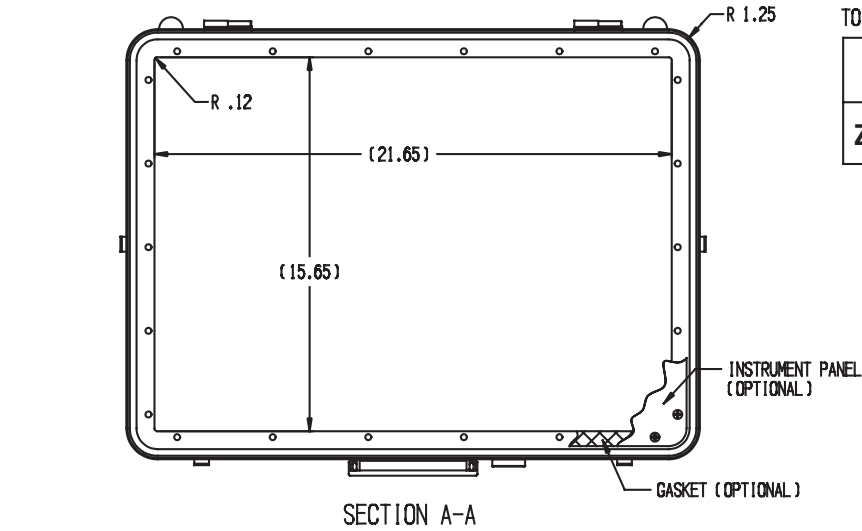

TO ORDER COMPLETE PART NUMBER BELOW:

CASE NUMBER	CLOSURE STYLE	VALVE TYPE	FINISH	OPTIONAL PANEL
Z112P	●	●	●	●

USE DASH NUMBER FROM PAGE 22

SEE PAGE 20 FOR OPTIONS

A FOR AUTOMATIC
M FOR MANUAL

SEE PAGE 22 FOR OPTIONS

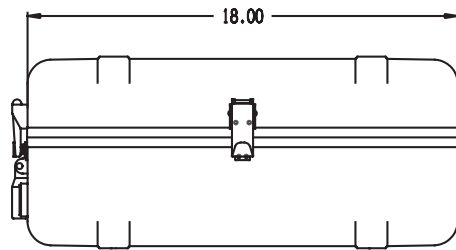
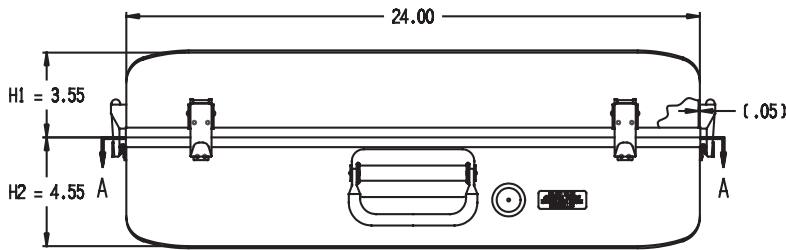

Z114P

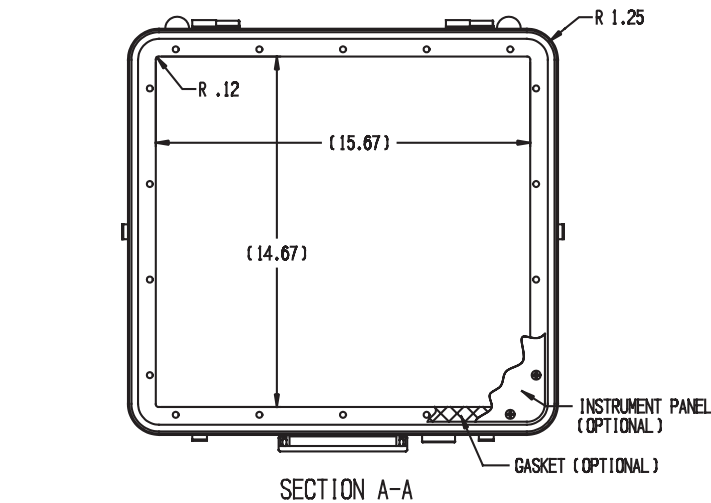

TO ORDER COMPLETE PART NUMBER BELOW:

CASE NUMBER	CLOSURE STYLE	VALVE TYPE	FINISH	OPTIONAL PANEL
Z114P	●	●	●	●

USE DASH NUMBER FROM PAGE 22

SEE PAGE 20 FOR OPTIONS

A FOR AUTOMATIC
M FOR MANUAL

SEE PAGE 22 FOR OPTIONS

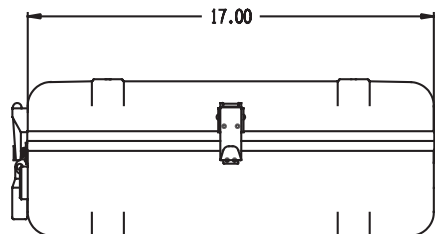
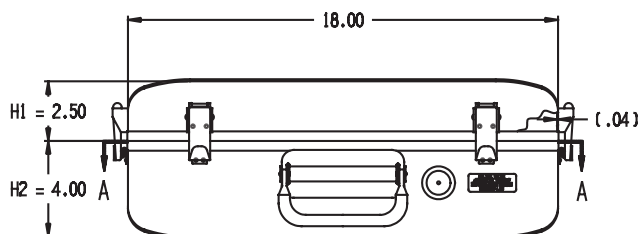

Z129P

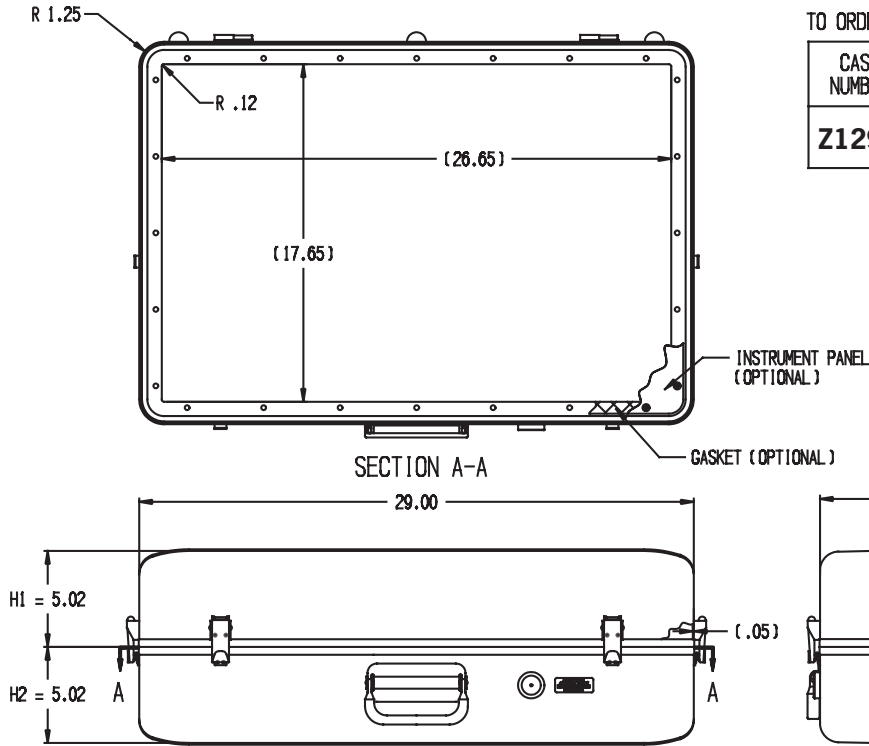

TO ORDER COMPLETE PART NUMBER BELOW:

CASE NUMBER	CLOSURE STYLE	VALVE TYPE	FINISH	OPTIONAL PANEL
Z129P	●	●	●	●

USE DASH NUMBER FROM PAGE 22

SEE PAGE 20 FOR OPTIONS

A FOR AUTOMATIC
M FOR MANUAL

SEE PAGE 22 FOR OPTIONS

Z132P

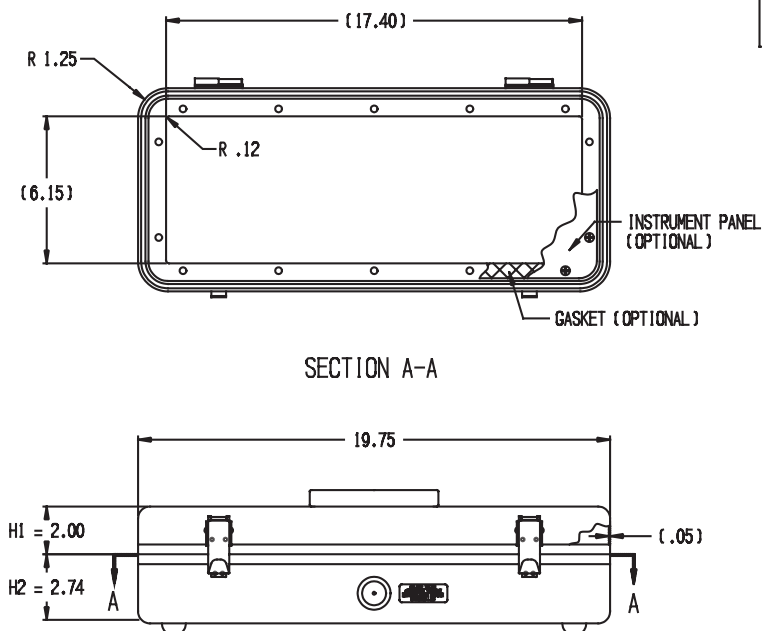

TO ORDER COMPLETE PART NUMBER BELOW:

CASE NUMBER	CLOSURE STYLE	VALVE TYPE	FINISH	OPTIONAL PANEL
Z132P	●	●	●	●

USE DASH NUMBER FROM PAGE 22

SEE PAGE 20 FOR OPTIONS

A FOR AUTOMATIC
M FOR MANUAL

SEE PAGE 22 FOR OPTIONS

NOTE: CASE SHELLS ARE NOT BEADED.